

The SAMBUCO tonearm - Installation Instruction 2026

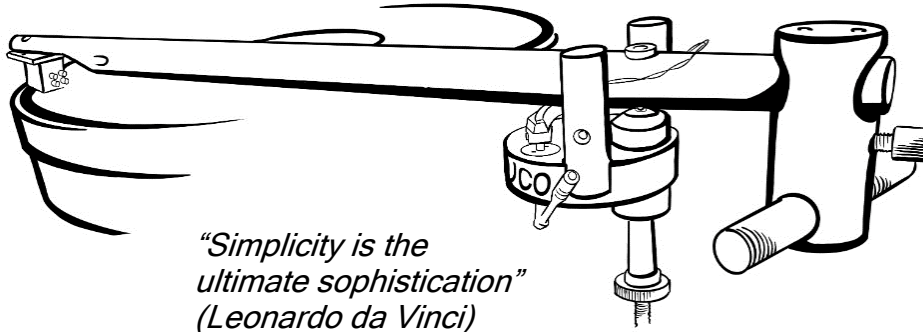

The SAMBUCO is a unipivot tonearm. Its name reflects the use of Sambucus Nigra wood for the tonearm pipe ("Elder wood"). The wooden pipe and all its internal and external treatments were inspired by the art of violin building. It is the secret of a resonance free support for your cartridge.

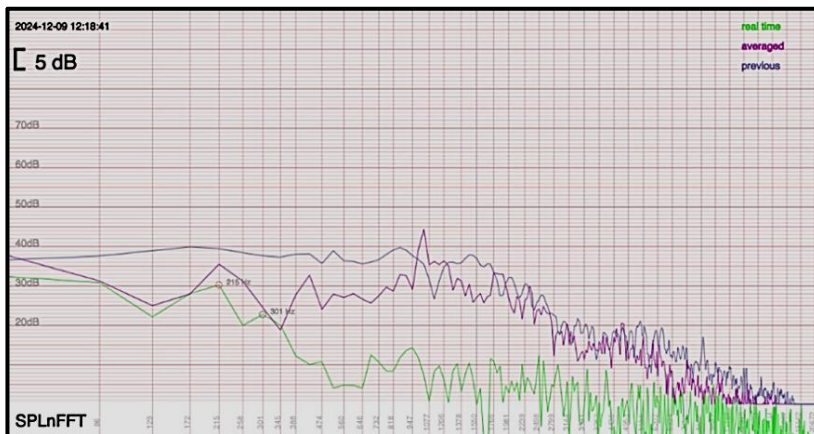

All SAMBUCO tonearms are impulse tested for their resonance spectrum, and leave the workshop only, if there are no discrete resonances measurable that have a high "Q" (equivalent to a "Wolf-tone" of a violin).

The bearing point is magnetically loaded to increase the bearing contact pressure by almost 1.5 kg in order to avoid bearing chatter and to transmit energy to the mounting base of your record player. Its design includes an eddy current damping at the point of the highest energy transmission to the arm board.

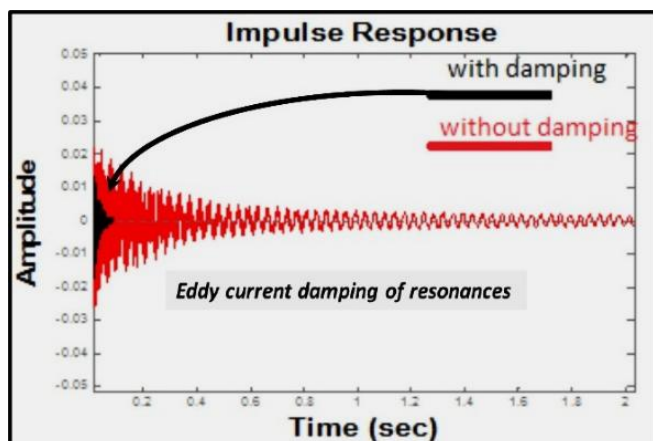

“Setting a unipivot tonearm is an iterative process.”

Do it step by step. No shortcuts please! I know it’s a pain, but “no pain, no gain”!

Apart from your precious patience, you will need:

- a drill bit (diameter: 6 mm),
- a good tonearm scale to weight the tracking force,
- a spirit level, to level your record platter before you start
- and some household DIY tools, like a small pliers, Allen keys, and screw drivers.

Important installation tip: You should always begin the installation job with a needle protector in place! (I am very unhappy that some cartridge designers omit a needle protector. Are they having second thoughts about earning additional money from repairing broken needles?)

A unipivot tonearm offers some additional degree of freedom to compensate for slightly off-centre needles and other artefacts of cartridge production. All SAMBUCO setting screws should initially only be slightly tightened. They might not be in their final position yet.

Table of contents

1. Drilling the tonearm base	3
2. Initial tonearm setting	4
3. The “INTERFACE”	5
4. Cartridge connection:	8
5. Transferring the SAMBUCO to your record player:	8
6. Fixing the tonearm cable	9
7. Bringing the tonearm into balance & downforce:	10
8. The lateral balance (Azimuth):	10
9. The SAMBUCO bearing:	11
10. Anti-Skating:	12
11. Final checks:	13
12. Security information, environmental concerns:	14

SAMBUCO Quick installation guide:

Please do have a look at the instruction videos on <https://www.sambuco.net/wp-content/uploads/2024/12/tonarm-installation1.mp4> step by step. Sometimes a short film is better than many words.....

Let's start:

1. Drilling the tonearm base

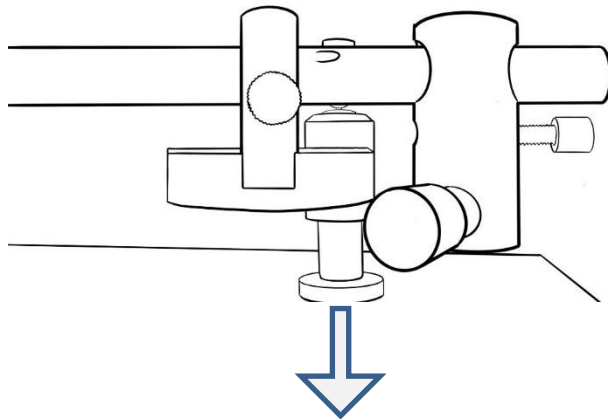

Only one single vertical mounting hole (6 mm diameter) for the M6 mounting stub (= vertical bearing position) has to be drilled into the tonearm board of your record player at a distance of 222.44 mm from the record centre (222 mm for the 10" (=240 mm) arm length, and 286 mm for the 300 mm (12") tonearm). Use the long template. This is for the Loevgren-alignment.

Put the 8 mm hole over your record platter centre. The 10 mm hole accommodates a pencil (centred!) to draw an arc on your tonearm base for the tonearm bearing position.

This arc will have the correct distance to the record centre.

Try to position the mounting hole along this arc so that there is enough space for all tonearm movements. Do have a look at the video!

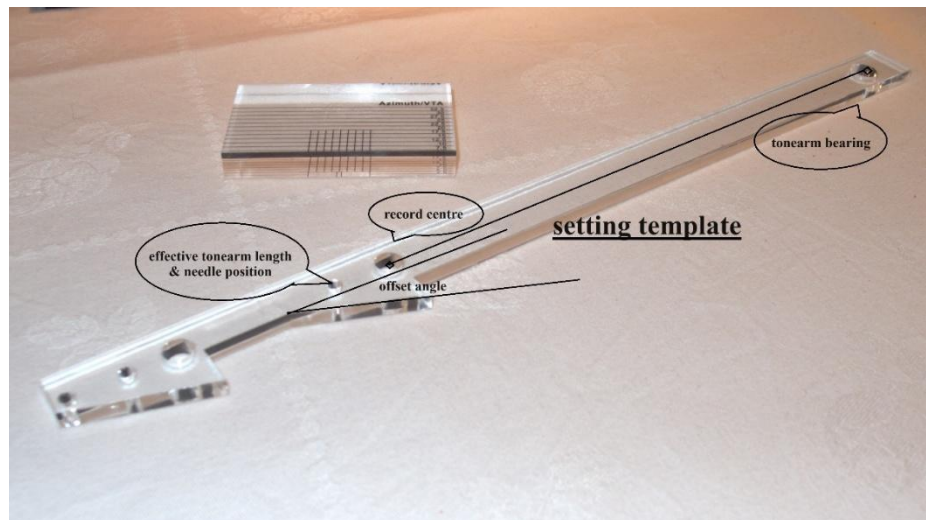

2. Initial tonearm setting



Before transferring the tonearm to your record player, you can do all further cartridge mounting work with good view and access from all sides.

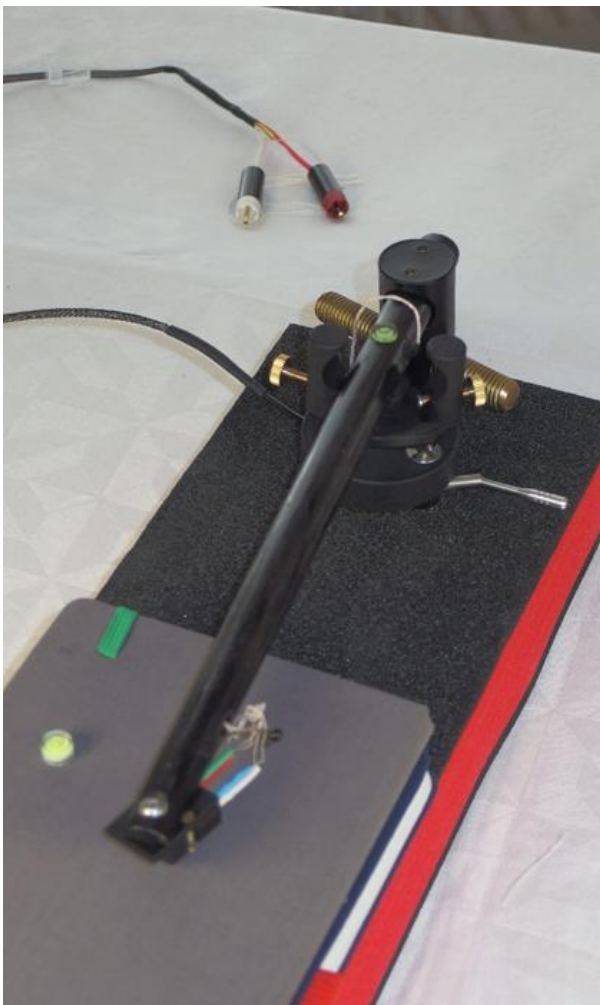

The SAMBUCO transport protection (the black and red foam block) is designed to facilitate your initial tonearm setting: Put the foam block on a plane and level surface in front of you. Choose one 6 mm hole to insert the mounting stub of the SAMBUCO base. The foam block simulates your tonearm base.

Put a plane surface (f.ex. a book) on the foam block to simulate the relative height (thickness) of your record platter.

3. The “INTERFACE”

The **SAMBUCO Interface** plays an important role: It links the cartridge to the tonearm, and it fixes the **offset angle**.

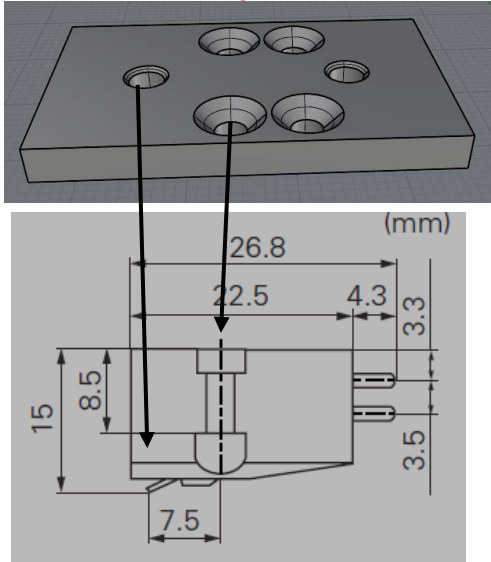

This is a small plate (30*24mm) that has 4 chamfered holes (1/2"; always on top). Your cartridge needs to be mounted under this interface with two countersunk screws. As a result, the needle of your cartridge shall be vertically positioned under an M4 threaded hole on the interface middle axis.

See the exemplary picture of a Denon DL103: The distance between the needle and the two mounting screws is 7.5 mm. You have to choose the right pair of chamfered holes for your cartridge.

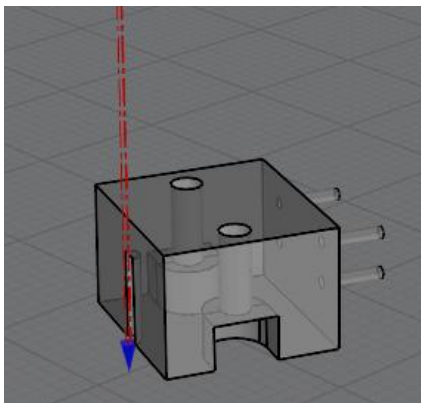

This is your **cartridge**:

Important is the position of the needle (diamond, in blue) to the mounting screw holes.

The red axis is exactly vertical above the needle.

This axis determines the correct Cartridge-INTERFACE alignment, and the correct effective tonearm length.

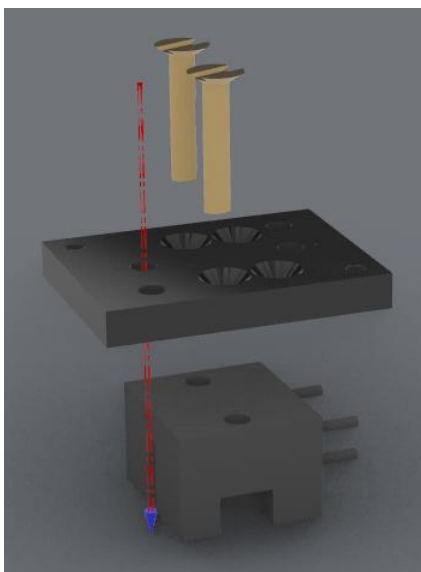

The **INTERFACE** will mechanically link your cartridge to the SAMBUCO tonearm. Notice the red axis, which determines the ideal combination: the front M4 hole is perpendicular above the needle.

The countersunk holes are for fixing your cartridge to the interface. Please choose those holes that position the front M4 hole above your needle.

(A tolerance of 1 mm does not cause any problem.)

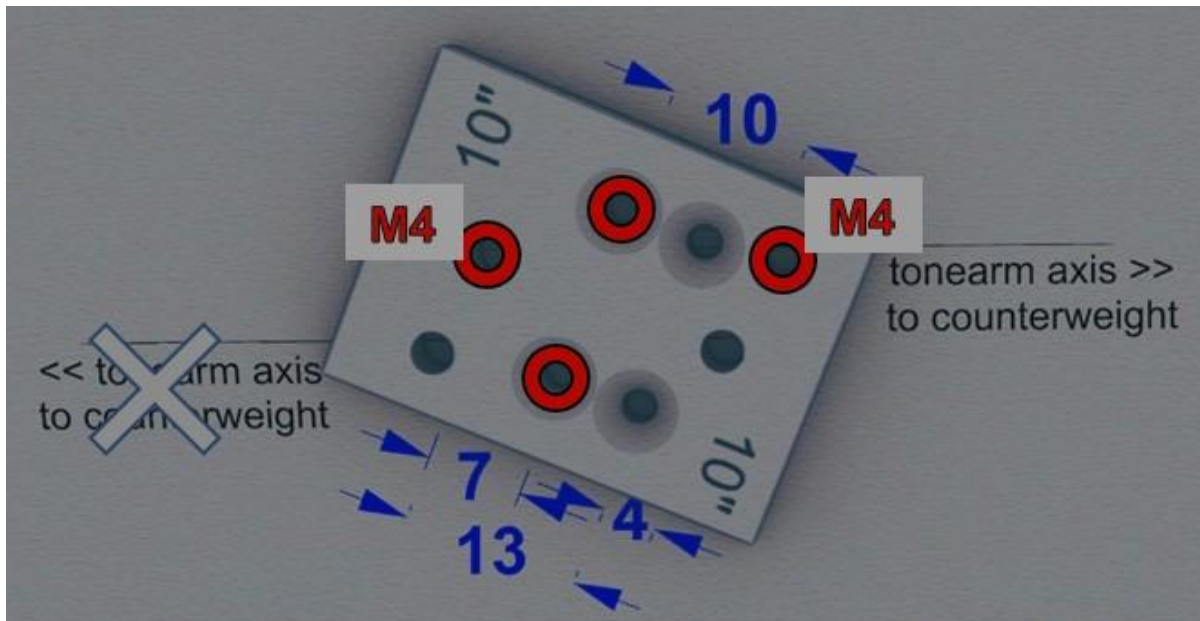

- **This example** (RED) accommodates a distance of **7 mm** (6-8 mm) between the needle (= front M4 hole) and the mounting screws.
- If you need to accommodate a bigger distance (12-14 mm), you should use the other pair of mounting holes for your cartridge.
- Rotate the interface by 180 degrees, and you can accommodate a 3-5 (4) mm distance, or 9-11 (10) mm.

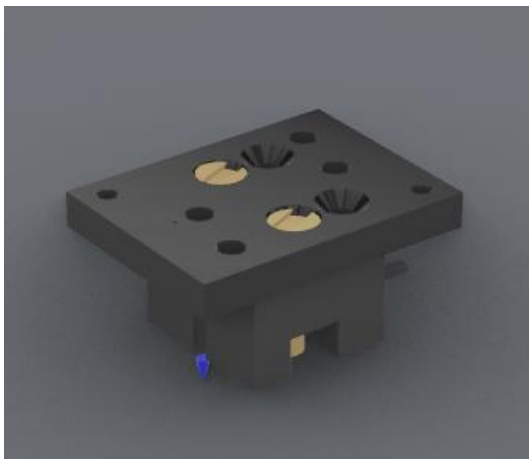

The interface ensures perfect geometrical alignment AND good mechanical coupling of your cartridge to the SAMBUCO tonearm. (*This is why Sambuco uses two head shell screws instead of only one!*)

The second rear M4 hole is drilled "off centre" at the correct offset angle: 22.2° for 10", and 18.02° for 12" tonearms. The correct interface is delivered with your tonearm.

(Note: Special interfaces f.ex. for "underhang" tonearms, that have no offset angle can be ordered separately. Remember underhung alignments need a different mounting hole distance between the record centre and the tonearm bearing.)

Now we can screw the interface (with the cartridge mounted) to the SAMBUCO tonearm.

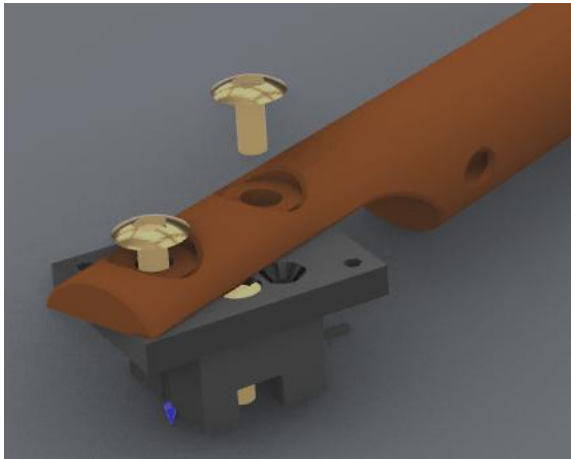

The tonearm has two M4 holes; First put the front M4 screw through the hole, and fix it to the Interface. Do not overtighten!

You need to rotate the interface (offset angle) until you can insert the second M4 screw.

The second tonearm hole is wider, to allow you to “fine tune” your offset angle. At this stage you could use the complimentary long plastic ruler, which is laser-cut at the exact offset angle. (=> There is a video on the homepage.) Now cautiously “tighten” the M4 screws, to eliminate any distance or “play” between the interface and the tonearm.

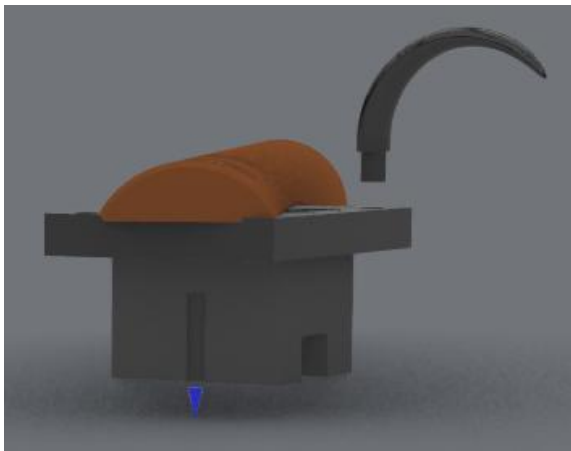

There is also a little finger-lift delivered. Just stick it into the little hole of the interface. There is no need to glue it, because you are lifting 2-3 grams downforce only! Once inserted, it will hold by its own.

Careful! The finger-lift is very light, non-resonant, but very easily breakable.



The long template helps to ensure the right offset. Put it on top of the SAMBUCO:

1) the 10mm diameter hole fits over the round spirit level.
2) At the cartridge end position the template hole representing the effective length of the tonearm over the front M4 screw.

3) From above look whether the cartridge body (or the interface) is parallel to the offset angle edge of the template.



If not: the 2nd M4 screw has a wider hole in the tonearm, to allow for fine tuning of the correct offset angle.

(The picture shows a 10" SAMBUCO.)

4. Cartridge connection:

Take care for the usual order: RED: right channel +, GREEN: right channel -, WHITE: left channel +, BLUE: left channel -.

(Not all contact stubs on cartridges have the same diameter. You might need to adjust the contact clamps on the wire. Widen them with a small peak (toothpick), or tighten them with the pressure of your fingers.)

You will notice a fifth wire: this is accompanying the signal wires to absorb any radio interferences picked up in the air and pulls it to "ground". Via the 5th (middle) stub of the DIN plug it will be connected to your phono cable shielding, and eventually to the earth/grounding post of your preamp. *Here the topic of HUM pops up:*

(Some cartridges have a metal enclosure that can be connected to this 5th wire, to become part of the shielding concept against hum and noise. One of the 2.5 mm brass screws that fix your cartridge to the Interface, can be used to build this electrical connection. (Be careful not to crack the interface by creating an uneven contact surface! Use the 2.5 mm countersink screw that is visible besides the tonearm.) Due to the internal wiring concept of some cartridges this might work to the contrary. They have connected shielding with one of the mass wires. "Trial and error" is your method of choice. (Some cartridges offer to additionally "ground" the metal encasement of the generator. (The old Shure V15 moving magnet allowed for this feature, if you had separated the metal encasement from the negative signal wire.)

Do not forget to ground the platter and/or the enclosure of your record player, to avoid hum!

Attention: The SAMBUCO tonearm cable was chosen for its tonal superiority. It is very thin (33 AWG) and might break if you pull it with force. Always push or pull the cable clamps, NOT the wire!

5. Transferring the SAMBUCO to your record player:

Insert the M6 mounting stub with the SAMBUCO tonearm base into the mounting hole on your record player.



One black M6 screw nut shall remain above the mounting board. It shall allow to adjust the VTA (= height of the tonearm above the record surface). Once your cartridge is in a parallel position to the record surface, the tonearm base has the correct height. From under the tonearm board you can now tighten the the second M6 steel nut until it is in touch with the tonearm board.

The tonearm, particularly the cartridge interface should be perfectly parallel to the record surface. This is ensured by raising or lowering the SAMBUCO arm base above the tonearm board with the mounting stub.

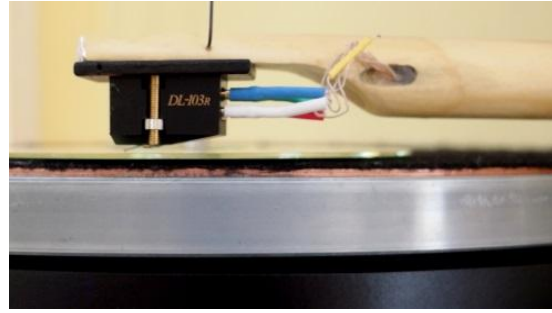

There is a second adjustment done by the same mounting stub: You can rotate the SAMBUCO tonearm base horizontally. On top of the (round) tonearm base you will see a small groove. It should point towards the record centre or slightly behind it. This ensures that the two anti-skating magnets are in a good position to do their job. Then finger-tighten the black M6 steel counter lock nut above the tonearm board to the tonearm base in this position. (I use a small pliers to tighten it with a clockwise rotation.) *This is important for a*

good energy transmission from the tonearm via its bearing into the tonearm board.

6. Fixing the tonearm cable

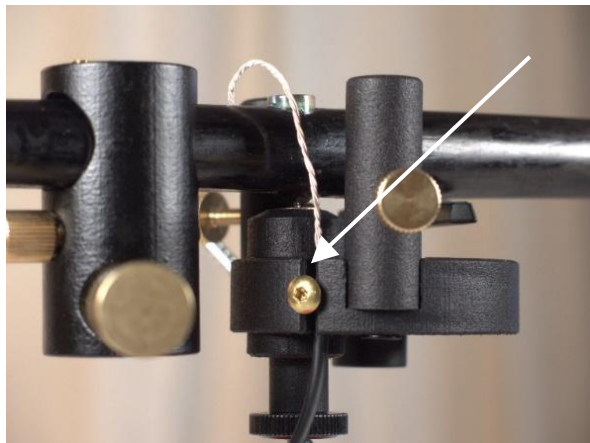

The tonearm cable shall be secured in a slot on the SAMBUCO base. This makes sure that the wire between the tonearm and the tonearm base stays in a defined arc, without mechanically interfering with tonearm movements. The tonearm cable is protected by a black shrink tube, and after approx. 30 cm ends in a standardised 5 pole male connection socket.

There you have to plug in your preferred phono cable (female 5 pole plug) that transfers the signal to your RIAA preamp (Cable not included). Since 2026 SAMBUCO tonearm cables are delivered with a 5 pole male DIN connector (diameter 12 mm). It can be positioned on your record player at a place convenient to attach your own tonearm cable. (You can fix it with a double sided tape, or screw it to the chassis or some convenient place.)

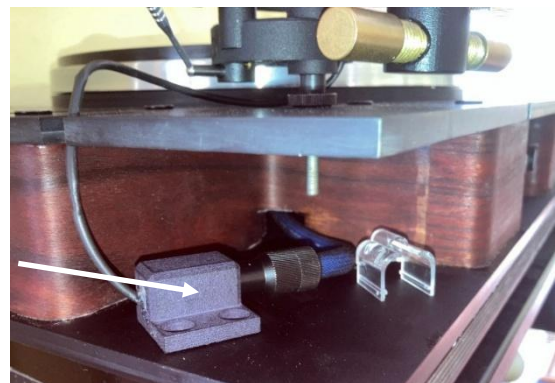

7. Bringing the tonearm into balance & downforce:

There are brass adjustment screws on the black counterweight:

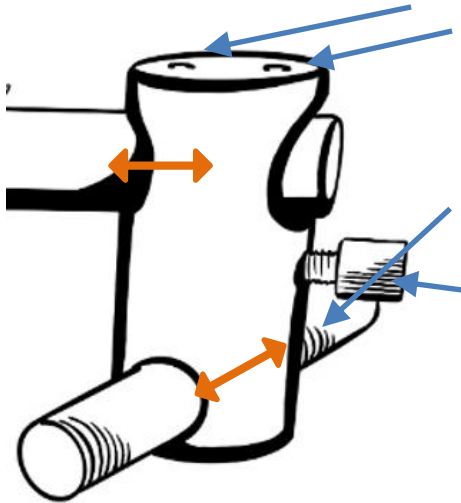

- 1) Two little M4 Allen screws on the top. If released, you can slide the counterweight back and forth.
- 2) One big M14 thread stub. If you turn it, you can adjust the lateral (left-right) balance of the tonearm (\leftrightarrow Azimuth adjustment).
- 3) One M6 stub for fine tuning the downforce.

Start by slightly unlocking the two M4 Allen key screws. You should then be able to slide the counterweight back and forth. Try to fix them again, when the recommended tracking force is roughly seen on your tonearm scale.

(Start with the needle protector in place and deduct its weight from the measured downforce.)
Fine adjustment (+/- 0.3 grams) will be done with the M6 brass stub (Clockwise rotation increases the downforce).

(Remark: I favour good energy transmission from the tonearm to the counterweight. More on this design philosophy at the end of this paper.)



8. The lateral balance (Azimuth):

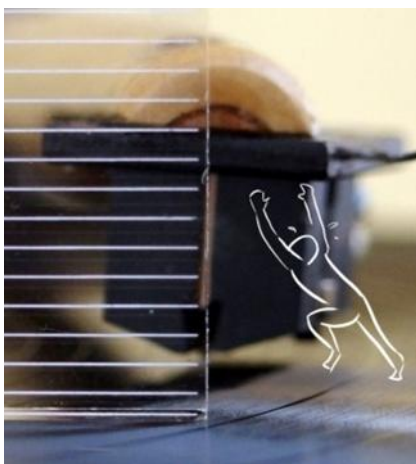

Your tonearm should ensure that the needle (without the protector now) is perfectly upright in the record groove.

There are two supportive tools delivered with your SAMBUCO:

- 1) The SAMBUCO tonearm has a small round spirit level above the bearing. Look, If the tonearm is "level"?
- 2) An Azimuth template with a number of horizontal and vertical lines. Put it in front of the cartridge on a record.

How to do adjust Azimuth? Lift the tonearm. Grab the counterweight with a firm, secure grip, then turn the big M14 brass stub (by hand). Just a little! This will change the lateral balance of the tonearm. It acts like the balancing stick of a tightrope artist. Re-check again. (Turning the M14 stub will slightly alter the downforce. Correct it with the M6 fine-tuning stub.)

Thoughts on static and dynamic balance

Imagine the SAMBUCO as a tightrope artist.



The **geometry and mass balance of the SAMBUCO tonearm** creates equal momentum forces around the bearing point: => almost no momentum differences at the needle tip of the cartridge. The bearing point and the centre of gravity are almost on the same plane as the record, so the tonearm should be immune to warp wow effects.

Explanation: The centre of gravity of the tonearm has to be slightly lower than the bearing point level, otherwise the tonearm would “capsize”. Do not worry if the tonearm seems to be a wobbling affair when you lower it on your record. It stabilizes soon after the needle is in the groove. The high performance of a good unipivot tonearm is defined by its balanced mass, not by a high bearing point level.

The **SAMBUCO counterweight** is designed to **add inertia** in the horizontal plane, like a balancing stick used by brave tightrope artists. Most tonearms offer a lot of inertia for vertical movements of the pickup diamond. Usually there is little left-right inertia to oppose **torsional diamond work in the groove**. The balancing stick is positioned 90 degrees against the cartridge cantilever axis (= the record groove axis). Apart from stabilisation it allows for fine tuning of the horizontal tracking angle (HTA or Azimuth), a critical set up topic for Uni-pivots.

9. The SAMBUCO bearing:

The bearing is a unipivot concept. It is enhanced by magnetic attraction, and an eddy current damping of the bearing point. Try to keep the copper bearing pan clean, so that the small steel bearing ball (part of the tonearm) can move unobstructed by dust or other little obstacles attracted by magnetism. For cleaning: cautiously lift the tonearm (You will have to overcome the magnetic loading (1.5 kg!) of the bearing point) to allow for cleaning the bearing pan (use a cotton stub with some isopropanol). After cleaning you can put just a drop of low viscosity oil into the bearing pan. (Less for damping, but more for lubrication and dust protection.)

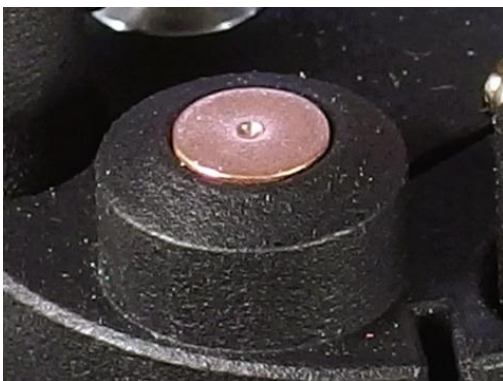

10. Anti-Skating:

The skating force is pulling your tonearm towards the record centre. This causes more pressure on the inner groove (**left channel information**). This force is not linear and has to be compensated to ensure good balance between left and **right channel information**.

The skating force starts relatively high, then decreases in the middle grooves, and then increases again at the final grooves. The anti-skating concept of the SAMBUCO takes care. It is based on 3 magnets. One is fixed under the tonearm. Two magnets are located in the small columns on the tonearm base. The outer magnet slightly “pulls” the tonearm, whereas the inner magnet “pushes” the tonearm in order to compensate the skating force.

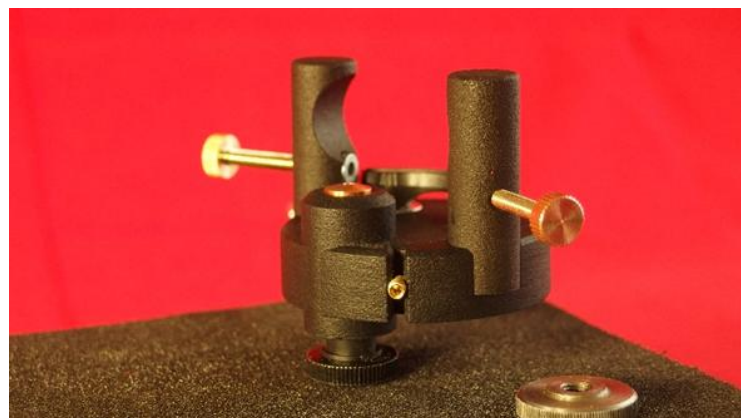
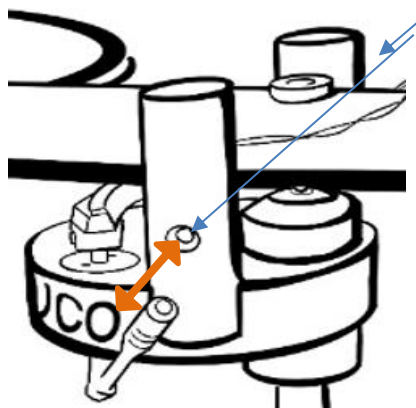
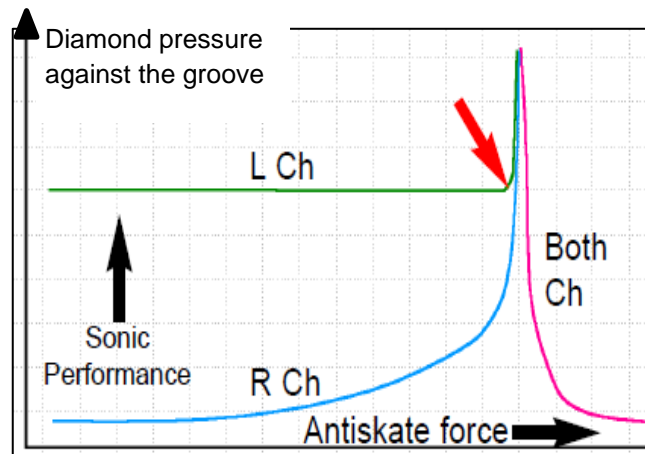

Turning the adjustment screws clockwise will lower the distance of the anti-skating magnets, and thereby increase the anti-skating force. If the anti-skating force is too high, then decrease the distance.

In situations where there is no need for anti-skating, I rotate the anti-skating columns away from the tonearm completely. (The brass adjustment screws are then almost parallel to the tonearm, because there is very little magnetic field 90 degrees off the magnetic axis.)

The Anti Skating Video will show how to tune anti-skating:

<https://www.sambuco.net/wp-content/uploads/2024/12/anti-skating-final.mp4>

Further fine-tuning is advisable and recommended with a good vocal record. Ideally you should use a mono recording. Normally singers are recorded to appear between your loudspeakers. If the voice is too far to the left, you will have to increase the antiskating force.

Do not underestimate your antiskating effort! The SAMBUCO will honour you with a great performance, and there is no additional cost.

11. Final checks:

All settings influence each other. It makes sense to check again. It is an “iterative” process!

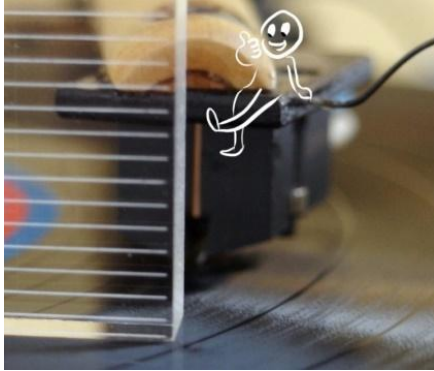

- 1) **Downforce (now without needle protector)**
- 2) **VTA and Azimuth:** Is the needle in a perfectly vertical position? Does the tonearm wire interfere with the free movement of the tonearm? “Dress it!”
- 3) **Tonearm lift:** Is the horizontal bar under the tonearm at a good operating height? (The tonearm lift is a REGA product. Adjustments can be done by loosening a (very) small screw to lower or higher the lift bar under the tonearm. Fix it again.

Connect your phono cable to the RIAA preamp and slowly increase the volume (no record yet). This exercise will tell you about any hum or noise interference. You might need to check your grounding wires and the physical position of the tonearm cable. Unfortunately, there are too many causes for hum, that I cannot list them here.

Enjoy, and remember: things improve after some “burn in” time.

Yours, Lukas Julinek - Vienna, Austria, 2026

Email: info@sambuco.net if you need support!

A final remark on some SAMBUCO design concepts:

I prefer **strong counterweight coupling** against springy links or even decoupling the counterweight. This is my interpretation of Isaac Newton's **impulse theorem**: If the mass of the moving parts of the cartridge (i.e. Diamond, cantilever, and coils) is very small against the total tonearm mass, then a maximum of the groove dynamics is transformed into electrical energy.

Imagine the SAMBUCO as the heavy mass of a seismograph that stays inert while an earthquake shakes the rest. The SAMBUCO opposes diamond acceleration in the groove with an inert balanced tonearm mass. The counterweight end of the SAMBUCO tonearm is a progressive energy sink. It aims for **low energy storage** and **minimum energy reflection**. Decoupled counterweights have the potential to store energy, and later give it back to the tonearm – at the wrong moment in time.

12. Security information, environmental concerns:

Like a violin the SAMBUCO is an expensive and sensible item. Do not expose the tonearm to heat, direct sunlight, or any other environment that a precious violin would not tolerate.

Electrically the tonearm is a passive element that transmits very small voltages generated from a pickup cartridge. Do not plug any tonearm wire (RCA plug) into any other connection, except the RIAA input of a pre-amplifier.

The SAMBUCO tonearm contains a number of different materials that were chosen for their acoustic benefits: wood, natural glue, epoxy glue, Nylon, neodymium, brass, steel, shrink pipe, natural oil, and wire. Depending on your location there might be different regimes about disposing these materials.

Any legal dispute will be settled in courts situated in Vienna, Austria.